

ASSEMBLY AND INSTALLATION INSTRUCTIONS

PACK RAT® Drawer Units - Model 301 through 338

IMPORTANT BEFORE YOU BEGIN

Read these instructions and warnings completely before installation.

Approximate Assembly and Installation time:
1 hour per unit (1.0 hrs.)
Depending on van or truck equipment installation experience.

The trademarked RED PUSHBUTTON is your assurance of WEATHER GUARD® Equipment quality.

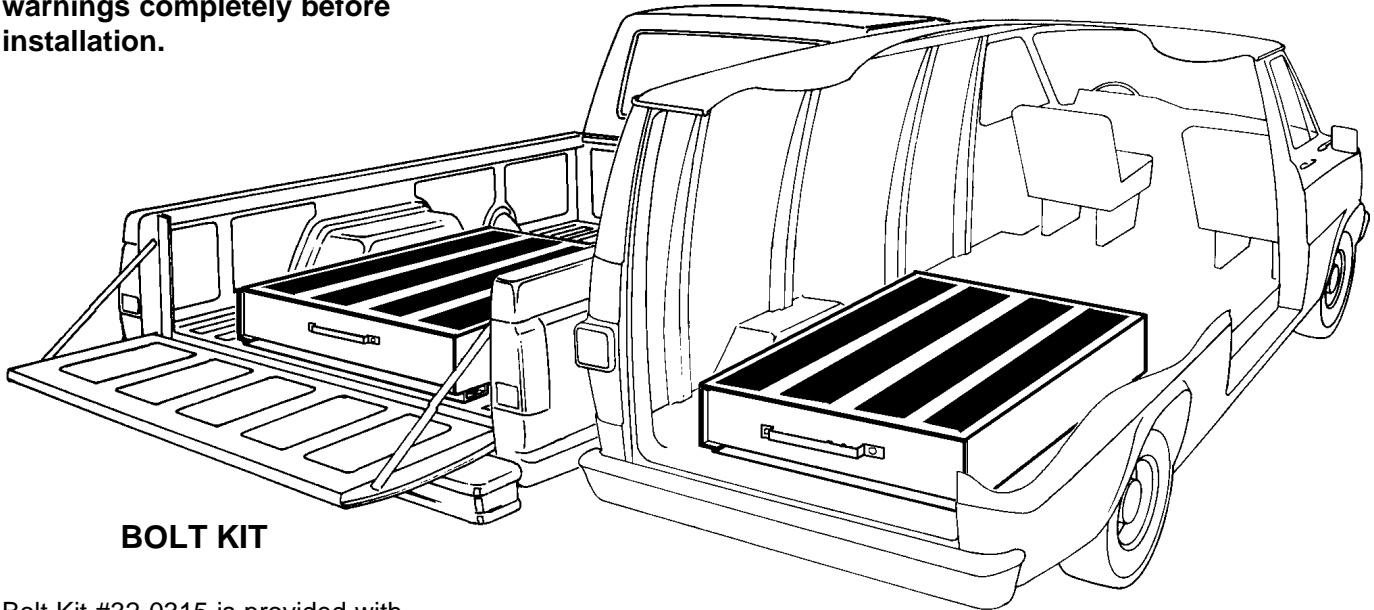

BOLT KIT

Bolt Kit #32-0315 is provided with your PACK RAT® Drawer Unit. Check this bolt kit to be sure the following parts are included:

Quan.	Description
4	5/16-18 x 1" Hex Hd. Bolt
6	5/16-18 x 1-1/2" Hex Head Bolt
1	5/16-18 x 2-1/4" Black Oxide Bolt
6	5/16" Lock Washer
10	5/16" Flat Washer
4	5/16-18 Nylon Lock Nut
6	5/16-18 Blind Fastener
1	Blind Fastener Installation Tool

HANDLE KIT #15-0005

1	Handle
2	5/16-18 x 1/2" Screw
2	5/16-18 Whiz Lock Nut

⚠ DANGER

Danger of explosion. Do not use this product for storing or transporting flammables, explosives, hazardous materials, or hazardous waste, such as containers of gasoline, gas powered equipment, solvents, gun powder, dynamite, propane tanks, acetylene tanks and cutting torches. This product is only intended and safe for use in storing and transporting small tools, equipment and other similar materials. Any modifications made to, or unintended use of this product, could create a hazardous condition that can cause death, serious personal injury or property damage.

PARTS LIST

- 1 - PACK RAT® Drawer Unit
- 4 - Mounting Plates
- 1 - Rear Mounting Bracket

TOOLS REQUIRED

- Screwdriver, common
- Electric Drill w/ 3/8" & 1/2" Bits
- Ratchet Wrench w/ 1/2" Socket
- 1/2" Open or Box End Wrench
- 9/16" Open or Box End Wrench

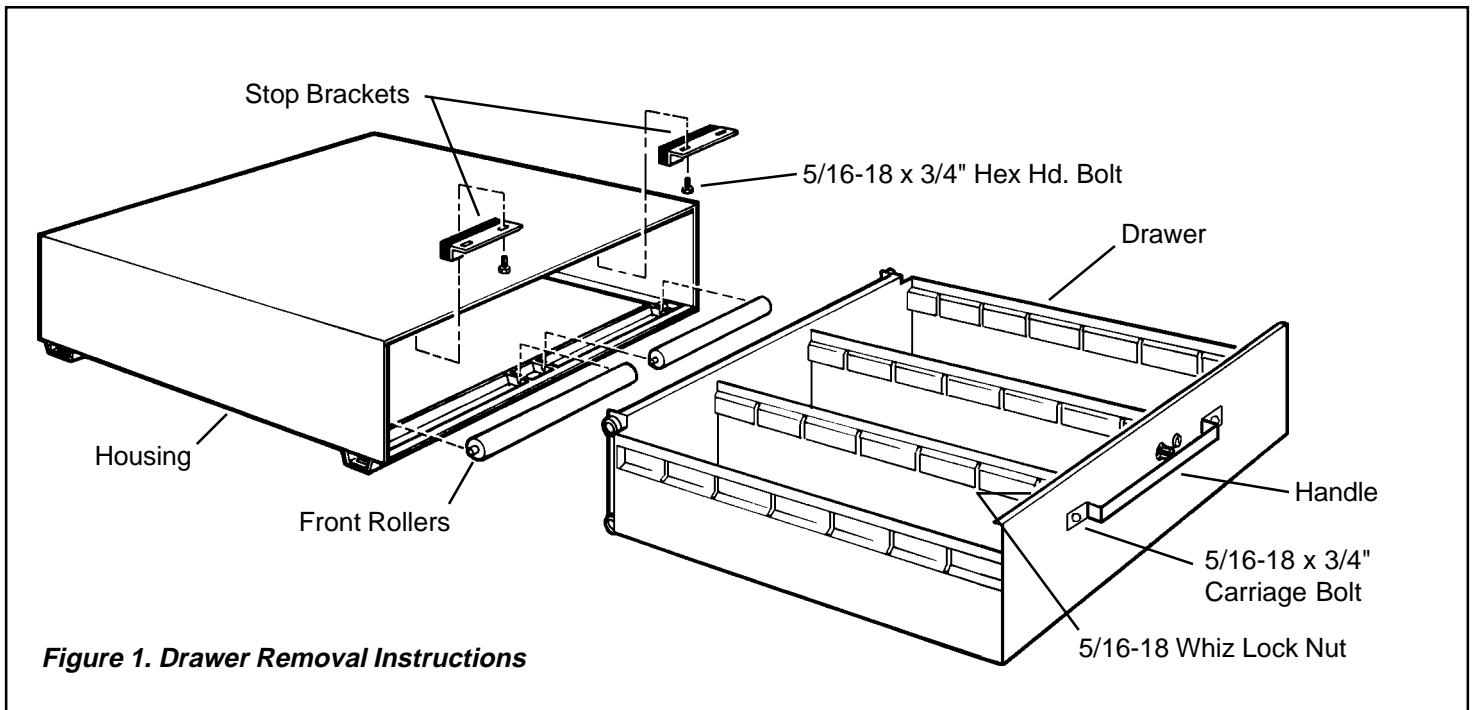

Figure 1. Drawer Removal Instructions

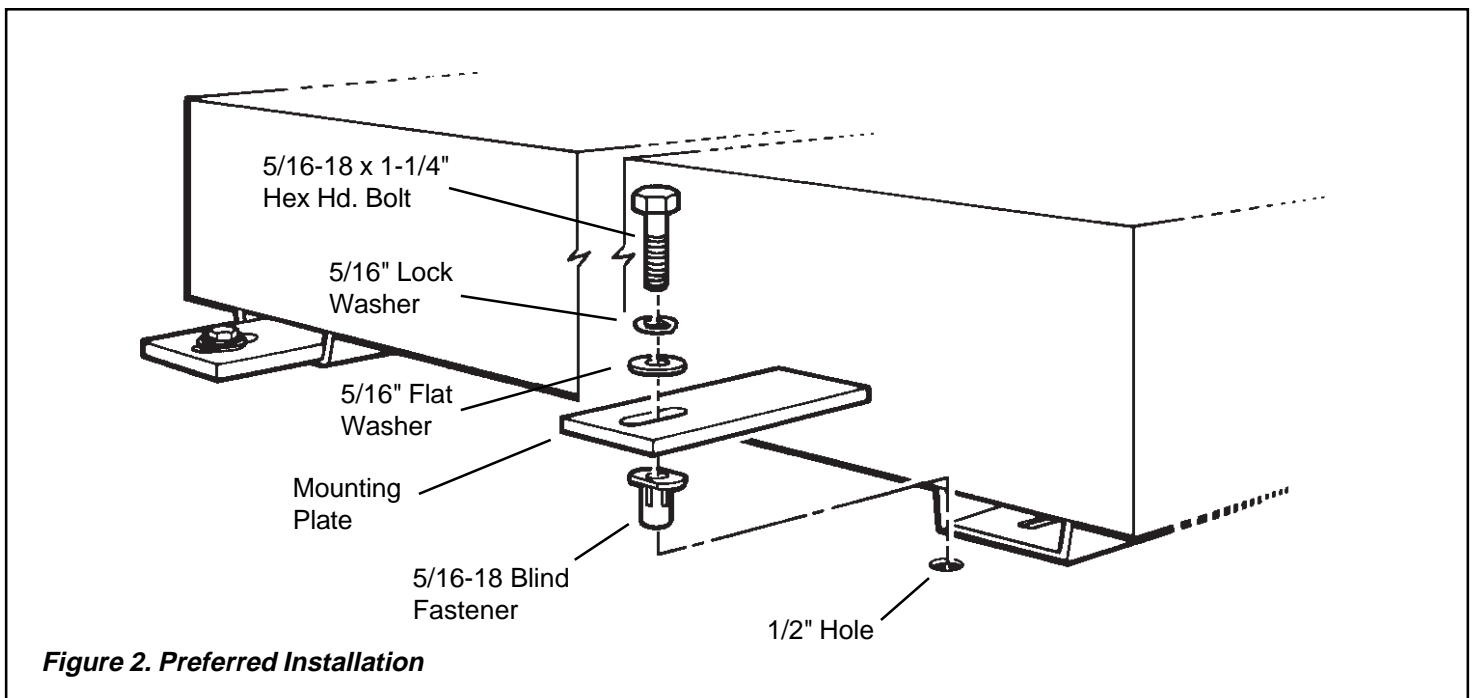

Figure 2. Preferred Installation

INSTALLATION INSTRUCTIONS

DRAWER REMOVAL

1. Open the Drawer until it reaches the internal Stop Brackets.
2. Remove the Stop Brackets from each upper inside location.

3. Put the brackets and bolts into the drawer for later installation. Install the Drawer Handle.

4. Carefully pull the drawer completely out of the housing, setting it aside. Lift out the Front Rollers. You are now ready to proceed with the installation.

⚠ CAUTION

Some of the larger drawers would best be handled by two people, so as not to cause injury to your person.

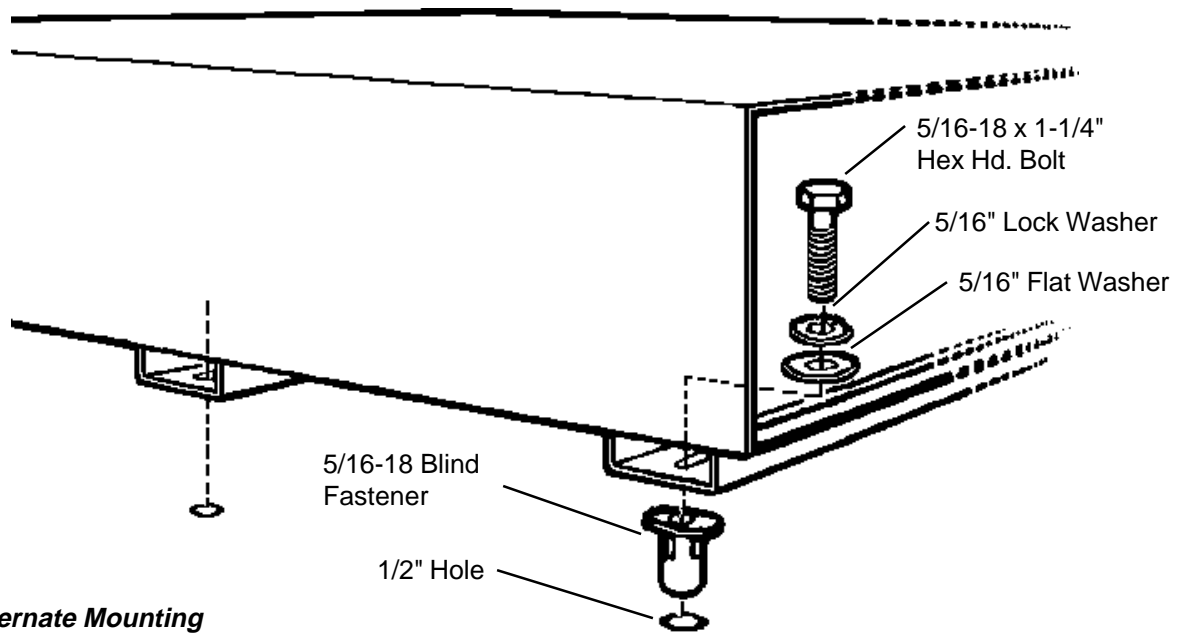

Figure 3. Alternate Mounting

PREFERRED INSTALLATION

(see Figure 2.)

NOTE: To prevent rust from occurring, touch-up any drilled holes.

1. Place the housing in position.
2. Slide a Mounting Plate into each open end of the front and rear skids, but no farther than the leading edge of the slotted hole in the Mounting Plate.
3. Mark through the hole for drilling. See Blind Fastener Installation Instructions and cautions before drilling.

⚠ WARNING

All floor mounting bolts near the gas tank area should be installed from the underside of the vehicle, to guard against the gas tank being punctured in the event of a collision. This would mean not using blind fasteners in this area. Holes drilled in this area should be 3/8".

4. With blind fasteners installed, secure by placing the Mounting Plate as you had for marking.

⚠ WARNING

The PACK RAT® Drawer Unit design will carry a generous amount of heavy cargo. You must use all four of the mounting plates; one at each corner. If this isn't possible, refer to the Alternate Mounting Instructions. Failure to comply could result in serious personal injury or damage to your vehicle.

ALTERNATE MOUNTING

NOTE: To prevent rust from occurring, touch-up any drilled holes.

1. Place the housing into the position, and mark through the outer slotted holes of each skid.

2. Remove the housing and read the Blind Fastener Installation Instructions and cautions before drilling each of the hole locations.

⚠ WARNING

All floor mounting bolts near the gas tank area should be installed from the underside of the vehicle, to guard against the gas tank being punctured in the event of a collision. This would mean not using blind fasteners in this area. Holes drilled in this area should be 3/8".

3. With all blind fasteners installed, secure the housing.
4. Reinstall the drawer to the unit by reversing the removal steps shown in Figure 1.

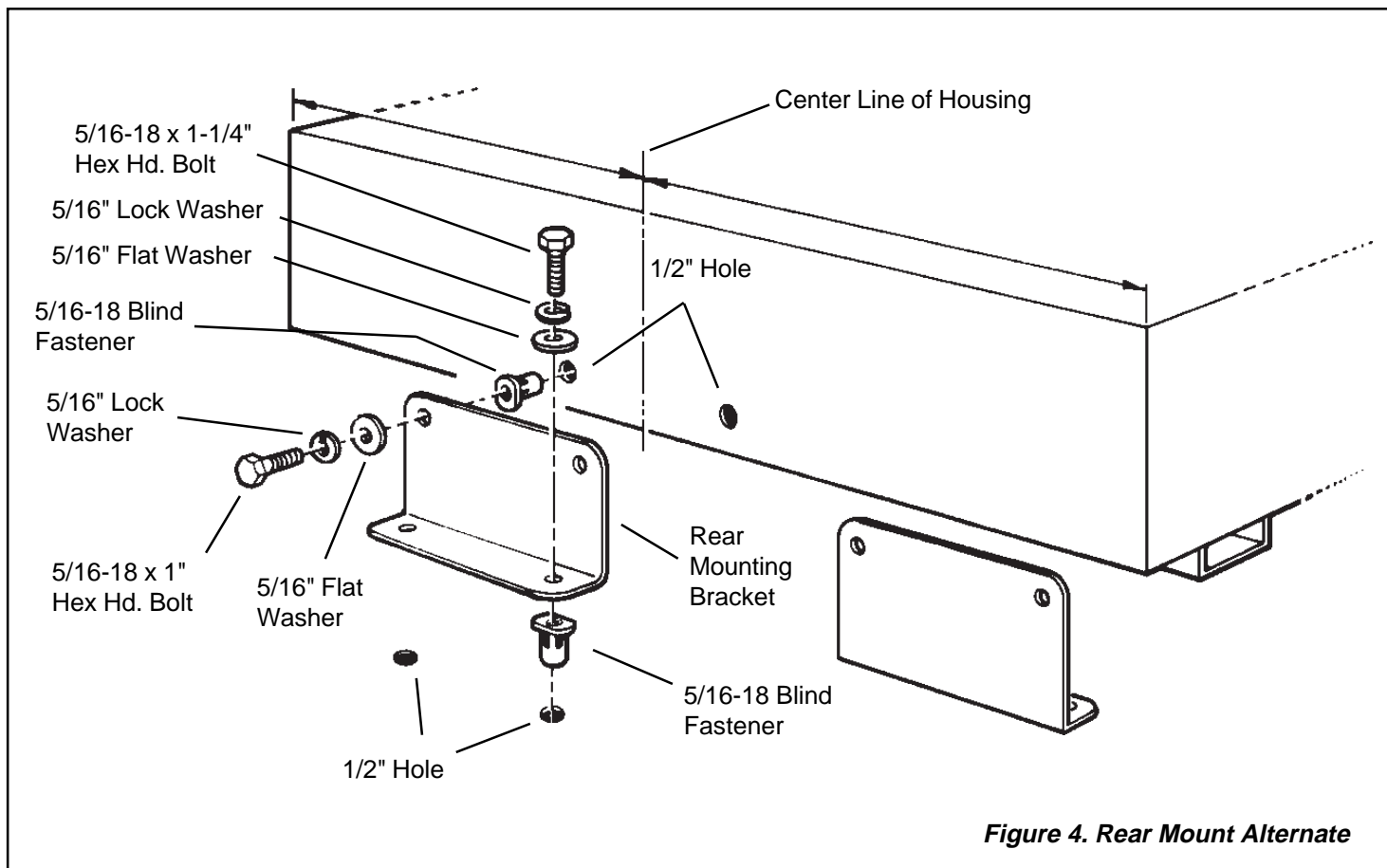

Figure 4. Rear Mount Alternate

REAR MOUNT ALTERNATE

NOTE: To prevent rust from occurring, touch-up any drilled holes.

1. If space is critical and/or for some reason you cannot mount the rear in either the preferred method or use the Mounting Plates at the rear, you may use the Rear Mounting Bracket.

2. Locate the center line of the housing and place the bracket flush against the back and flush to the floor. If necessary, you may turn the bracket so the floor flange is under the rear overhang of the housing. Hole marking will be more difficult.

3. Mark **only the two floor holes** for drilling. See Blind Fastener Installation Instructions and cautions before drilling.

⚠ WARNING

All floor mounting bolts near the gas tank area should be installed from the underside of the vehicle, to guard against the gas tank being punctured in the event of a collision. This would mean not using blind fasteners in this area. Holes drilled in this area should be 3/8".

4. With blind fasteners installed, fasten the bracket to the floor.

5. Mark and drill holes on the back of the housing for blind fastener installation.

6. With blind fasteners installed, replace the housing and secure to the bracket.

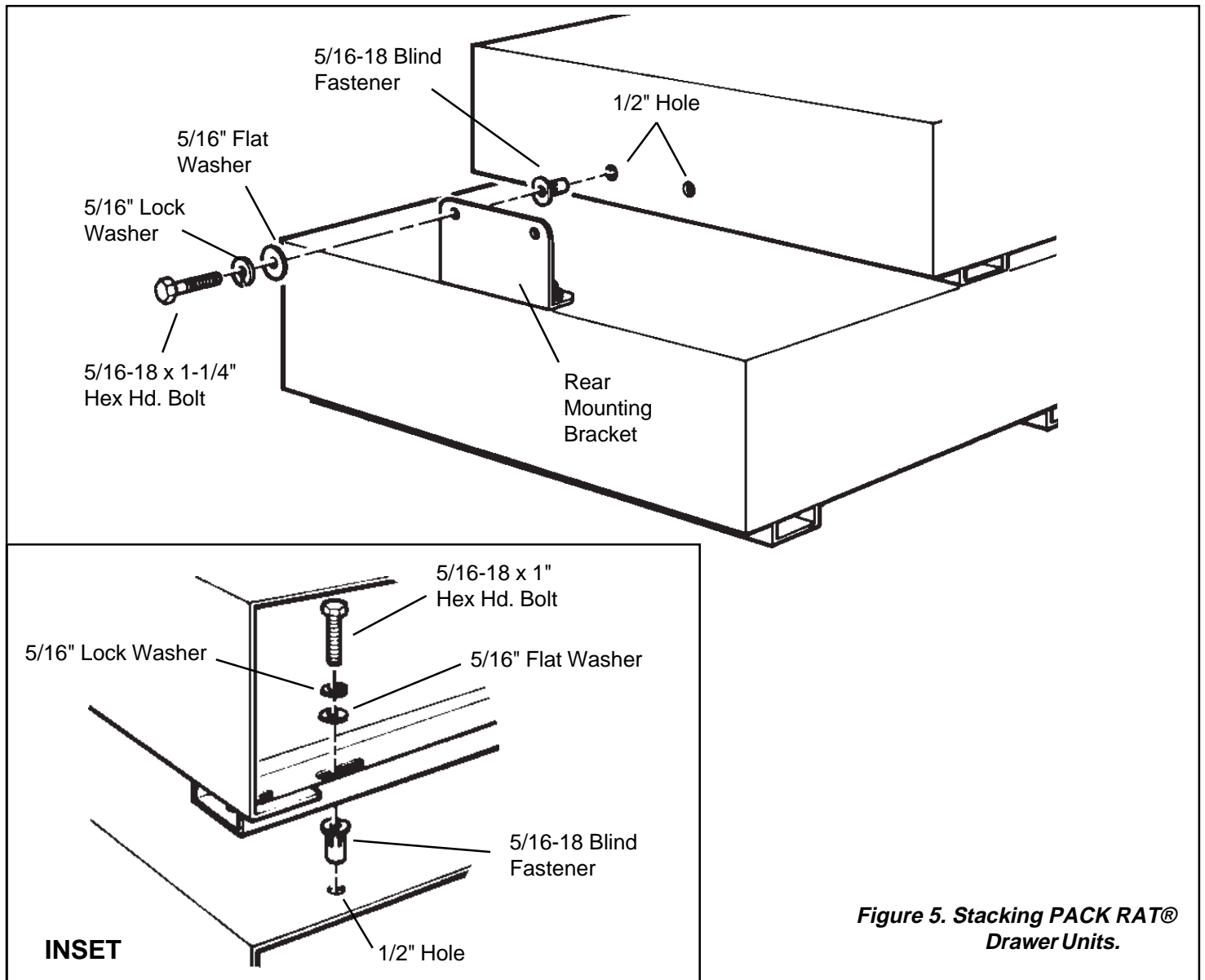

Figure 5. Stacking PACK RAT® Drawer Units.

STACKING PACK RAT® Drawer Units

NOTE: To prevent rust from occurring, touch-up any drilled holes.

NOTE: When stacking PACK RAT® units in an open vehicle, apply sealant (local purchase) to drilled holes in the Drawer Unit bodies.

1. With the lower PACK RAT® unit properly bolted in place, mount the Rear Mounting Bracket to the top rear edge of the unit as shown.

2. As with *Figure 4.*, the bracket will be mounted to the bottom first.

3. Put the upper PACK RAT® unit in position on top of the lower and mark the back mounting holes for blind fastener installation.

NOTE: Do not install bolts in the rear of the upper housing at this time.

4. With the upper housing in proper bolting position (with drawer and rollers removed), mark through inner two obround holes in the front mounting skid for blind fastener installation.

NOTE: See *Figure 5. Inset* for installation details. Do not use outer-most obround holes, fasteners would obstruct lower unit drawer travel.

5. With front blind fasteners installed, fasten the upper housing to the lower.

⚠ WARNING

The PACK RAT® Drawer Unit design will carry a generous amount of heavy cargo. You must use all of the mounting materials provided as specified. Failure to comply could result in serious personal injury or damage to your vehicle.

INSTALLATION PROCEDURE USING BLIND FASTENERS

⚠ WARNING

Prior to drilling, so as not to cut or puncture fuel tanks, fuel lines, brake lines, electric wires, etc., check under vehicle for locations.

Place a drop of oil on the black oxide bolt before assembling as shown on right. Place the Blind Fastener in the hole and use a 1/2" or 7/16" wrench to tighten black hex bolt until the blind fastener is fully seated. When setting black hex bolt, it will start out hard. As the Blind Fastener "bulbs" out it will get easier, until it bottoms out or sets. Make sure the Blind Fastener and Installation Tool do not turn during installation.

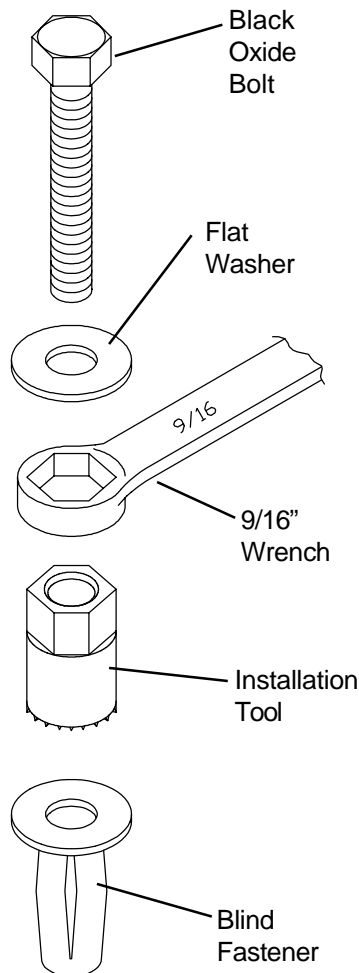

WEATHER GUARD® PRODUCT REFINISHING PROCEDURES

All WEATHER GUARD® products are finished with a polyester powder coating, and it is important to follow these procedures to get proper adhesion. As Knaack Manufacturing Co. cannot control the finishing of the products, the warranty for WEATHER GUARD® products on paint is not applicable on refinished products.

1. Sand the surface to be painted with 180-200 grit sand paper to rough up the surface. This should be followed by wet sanding with a 400 grit wet or dry paper.

2. Wipe down the sanded surface with ketone based thinner. This removes the dust and softens the powder coating for better paint adhesion.

3. Wipe sanded area with a tack rag to remove loose dust and particles before painting.

NOTE: Do not use a lacquer over the powdered coating.

- NOTICE -

Any modification or unintended use of this product shall immediately void all manufacturers warranties. Manufacturer disclaims all liability for injuries to persons or property resulting from any modification to, or unintended use of this product.

If you have any questions, please give us a call. **Call Toll Free 1-800-456-7865**

WEATHER GUARD® products are protected by one or more of the following trademarks:
U.S. - 842268, 1367500, 1661625, 1663369, 1676545, 1882062, 2228051, 2362167, 4573731; Canada - 1224230, 282725, 297499;
U.K. - 1400720, 1402476; N.Z. - 296049; Aus. - 761964

**KNAACK
MANUFACTURING
COMPANY**

KNAACK MANUFACTURING COMPANY
420 E. TERRA COTTA AVENUE
CRYSTAL LAKE, ILLINOIS, 60014 U.S.A. 815-459-6020

©2001 Knaack Manufacturing Company

